

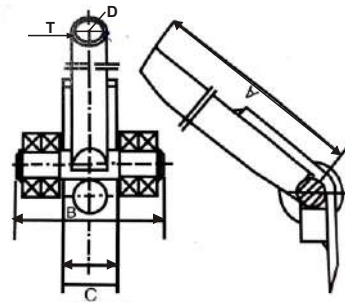

**Model: RC**

## ROLLER CROWBAR

A lever bar of strong steel tube on two smooth running steel rollers.



- Compact design
- Easy to use
- High efficiency
- Safe handle

Product code	Capacity (Ton)	Roller Skate Max.height Recommended (mm)	Tube Length (mm) A	Width (mm) B	Distance between two wheels (mm) C	Tube Size dia×thickness (mm) D×T	N.W. (kg)
RC 30	3	110	1400	136	50	Φ34×4	7.0
RC 50	5	110	1500	162	68	Φ38×5	10.5